

# Assembly instruction

## Swivel for original seat PSA /Toyota van



### Seat connections | PSA/Toyota

#### as well for:

Peugeot *Expert + Traveller*

Citroen *Jumpy + Space Tourer*

Toyota *Pro Ace + Pro Ace Verso*

Opel *Zafira Life*

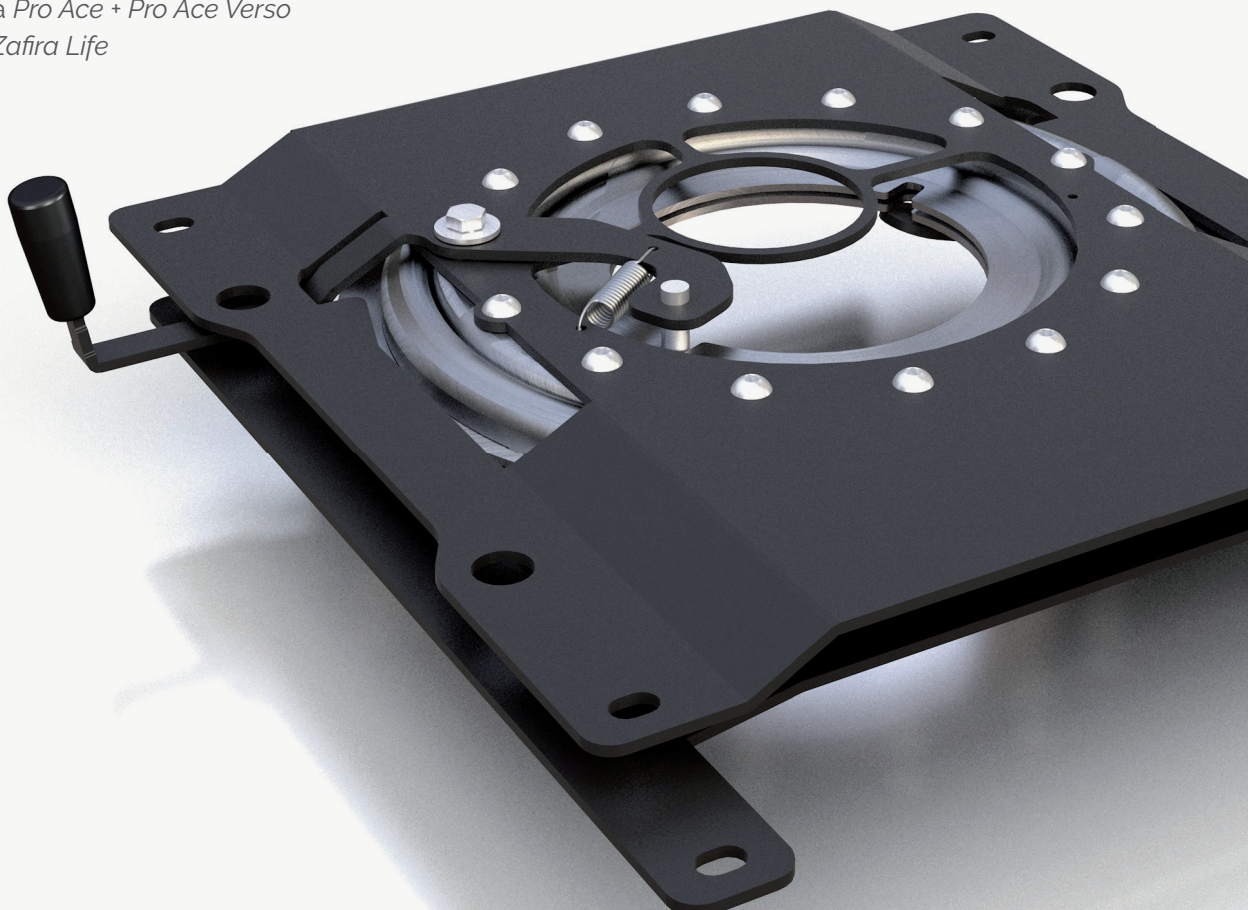

#### Specification: PSA/ Toyota

Mounting kit: ECE 911 300 103

Drawing: 680-278-00

Aguti Art.No.: 120440 F / 120441 BF

Aguti test report: GTÜ R014-19020.00

[www.aguti.com](http://www.aguti.com)

# Fixing material and assembly tool

## Swivel for original seat PSA / Toyota van

### Material

Pcs.	Sign	Size	Description
4 ×	<b>a</b>	M10x25	Lens head screws (10.9) <i>DIN EN ISO 7380-2</i>
4 ×	<b>b</b>	M10x12	Lens head screws (8.8) <i>DIN EN ISO 7380-2</i>
4 ×	<b>c</b>	M10	Nuts (8) <i>DIN EN ISO 4035</i>



Loosen screws



Screw by hand



Tighten with torque



Function test

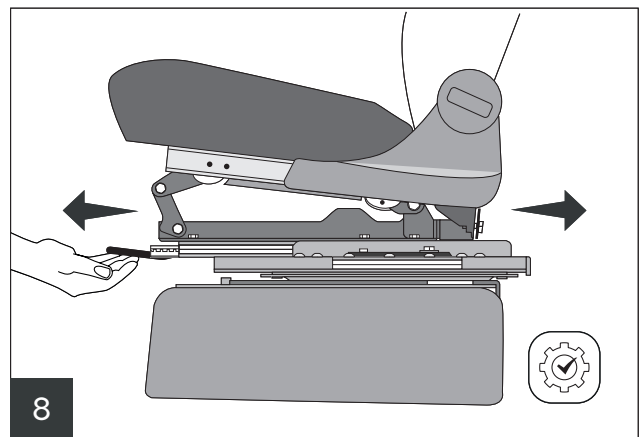
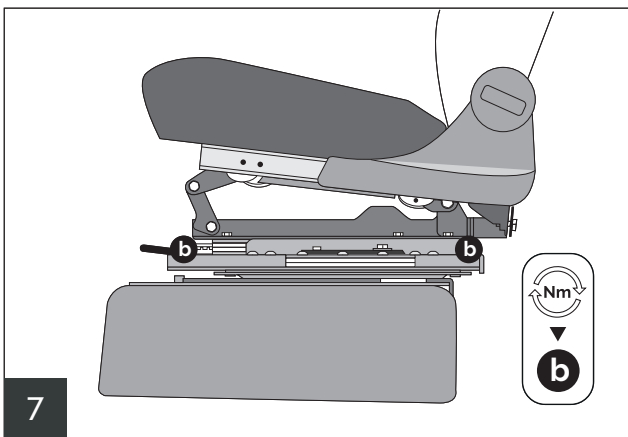
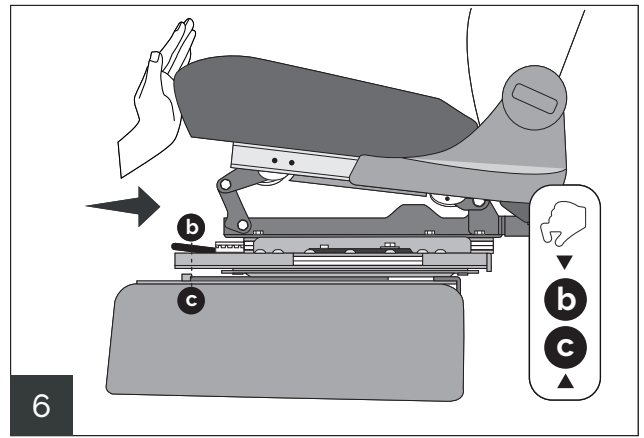
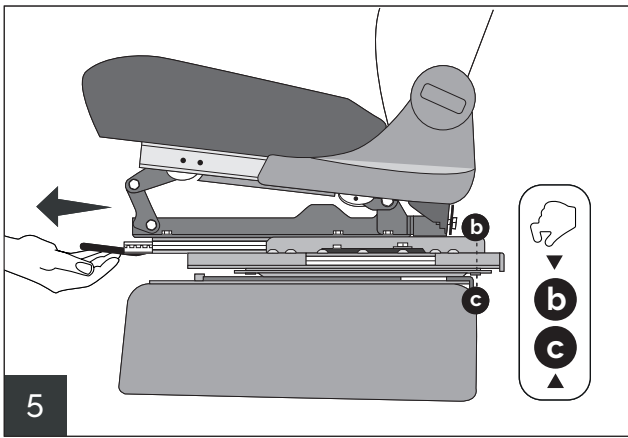
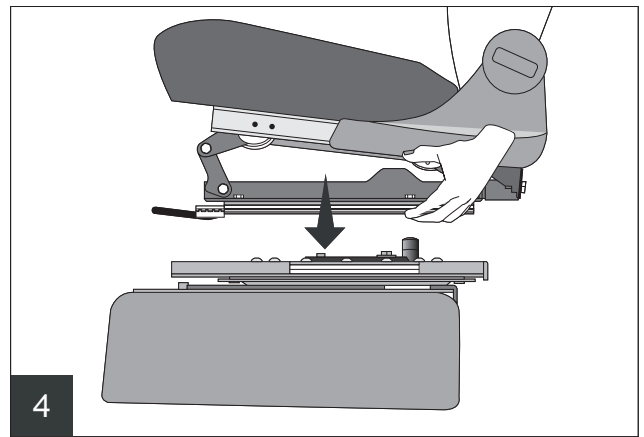
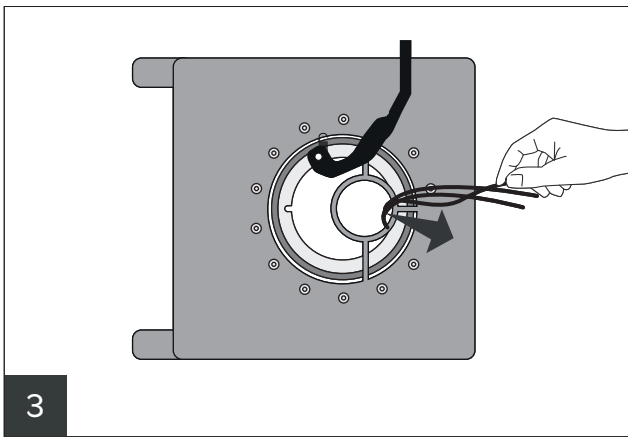
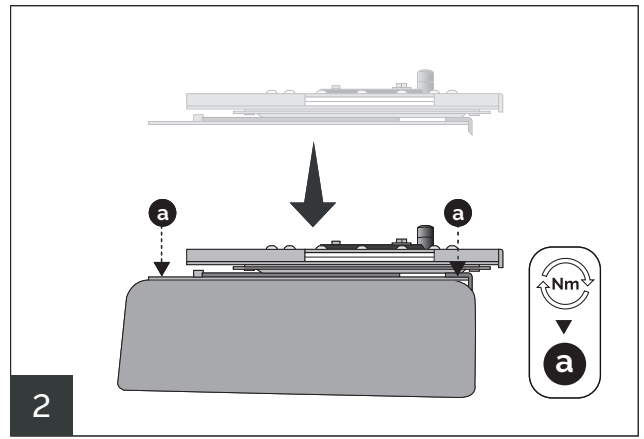
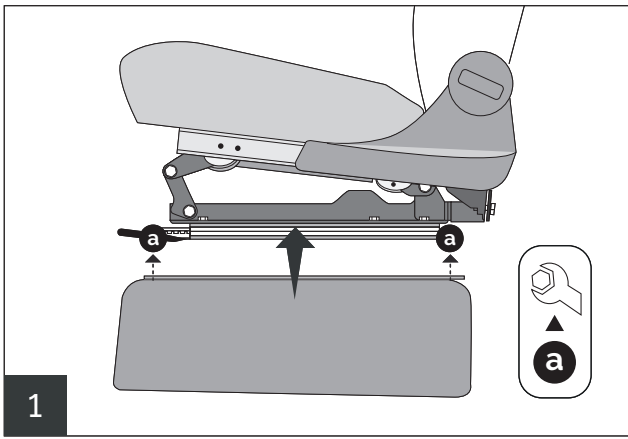

# General information

## Warranty

1. If the buyer is an entrepreneur, we offer a guarantee for defects in the item of either rectification or replacement delivery. However, we are entitled to refuse the type of subsequent performance chosen if this is only possible at an unreasonable cost and if the other type of subsequent performance does not cause a significant disadvantage to the consumer.
2. If the purchaser is a consumer, he or she can first choose whether the subsequent performance will take place by way of rectification or replacement delivery. However, we are entitled to refuse the type of subsequent performance chosen if this is only possible at an unreasonable cost and if the other type of subsequent performance does not cause a significant disadvantage to the consumer.
3. If the type of subsequent performance chosen by the customer is unsuccessful, i.e. if the defect is not rectified or if a fault-free item is not delivered, the customer can fundamentally choose to either lower the compensation (reduction) or have the contract nullified (withdrawal). However, in the event of an insignificant contractual violation, particularly for insignificant defects, where the subsequent performance chosen by the customer is only possible at an unreasonable cost, the customer shall not be entitled to a withdrawal.
4. Entrepreneurs must report obvious defects in writing within the time laid down in section 377 HGB; otherwise the right to assert guarantee claims shall be excluded. If the notification of defect is sent in a timely

manner, the deadline is considered to have been met. The burden of proof falls entirely to the entrepreneur for all claim requirements, particularly for the defect itself, for the date when the defect was discovered and for the timeliness of the defect complaint. Consumers must inform us in writing of any obvious defects, within 2 months of the date when the goods were discovered to be in violation of contractual standards. Compliance with this deadline is based on receipt of the notification by metalfoam. If the consumer fails to provide such notification, the guarantee rights shall lapse 2 months after the defect is discovered. This does not apply in the event of malice on the part of the seller. The consumer shall bear the burden of proof for the date the defect was discovered. If the consumer was persuaded to purchase the item through inaccurate claims by the manufacturer, the consumer shall bear the burden of proof for its purchasing decision. For used goods, the consumer shall bear the burden of proof for the item's defectiveness.

5. If, due to a legal or material defect, the customer chooses to withdraw from the contract, the customer shall not be entitled to any additional damage claims due to the defect. If the customer chooses to claim damages after an unsuccessful subsequent performance, the goods shall remain with the customer if this is reasonable. The damage compensation shall be limited to the difference between the purchase price and the value of the defective item. This shall not apply if we maliciously committed the contractual violation.

6. For entrepreneurs, the guarantee period is 1 year as of the delivery or transfer of the goods. For consumers, the grace period shall be 2 years as of the delivery of the goods. However, this shall not apply if the customer does not notify metalfoam of the defect in a timely manner corresponding to the notification period given in Point 4.

7. If the purchaser is an entrepreneur, only the manufacturer's product description shall determine the agreed characteristics. Public statements, claims or advertisements by the manufacturer do not constitute contractually guaranteed characteristics of the goods.

8. The client does not receive warranties in the legal meaning from us; warranties of the manufacturers will remain unaffected by this.

9. If the customer receives deficient assembly instructions, we shall be merely obligated to supply defect-free assembly instructions and this also only if the defect in the assembly instructions stands in the way of proper assembly.

## § 9 Limitations of liability

1. In the event of slightly negligent violations of obligation, our liability shall be limited to the average direct damages that are foreseeable and typical in contracts for this type of goods. This also applies to slightly negligent violations of obligation by legal representatives, managing employees and other agents. In the event of a slightly negligent violation of insignificant contractual obligations, we shall not be liable to entrepreneurs.

2. The present liability limitations do not apply to the customer's claims arising from product liability. Furthermore, the liability limitations do not apply to attributable damages to body or health, or in the event of the customer's loss of life.

3. The customer's damage claims due to a defect shall lapse one year after the delivery or transfer of the goods. This shall not apply if metalfoam can be accused of malice, or in the event of attributable damages to body or health, or in the event of the customer's loss of life.

Torque table			
	Strength class Nm		
	8.8	10.9	12.9
M4	2.2	3.2	3.8
M5	4.3	6.3	7.3
M6	7.4	10.9	12.7
M8	17.9	26.2	30.7
M10	36.0	53.0	61.0
M12	60.0	90.0	105.0
M14	-	-	-
M16	60.0	-	-
M20	-	-	-
M24	-	-	-
7/16'	40.0		
<b>7/16 screws are to be fixed with medium strength thread locking.</b>			
<b>Deviation of maximum permissible torque</b>			
Screws up to M8	12%+- deviation		
Screws up to M16	10%+- deviation		
Screws up to M24	5%+- deviation		
Screw 7/16	5%+- deviation		